

MASTER 5000

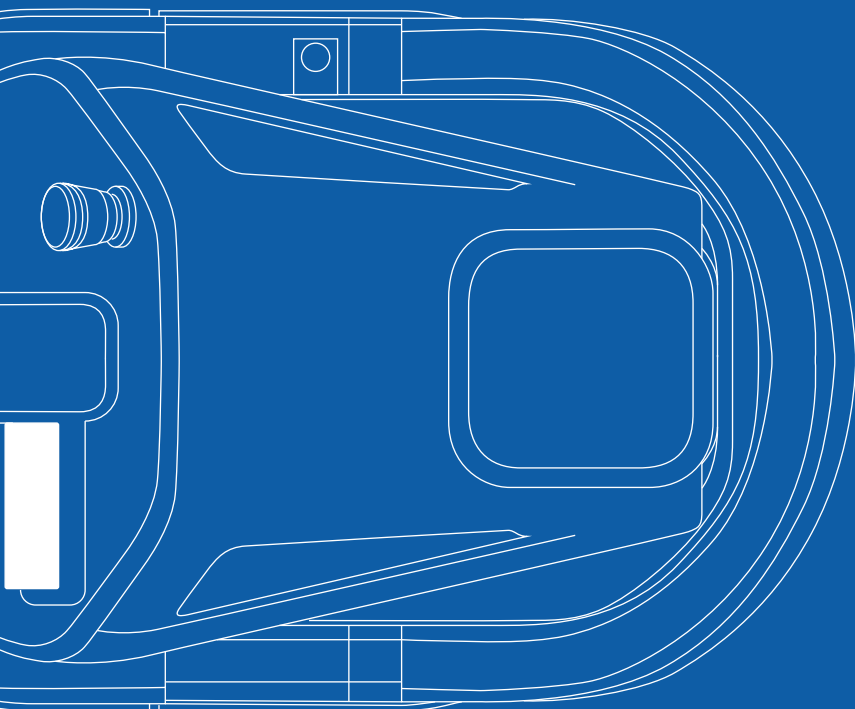

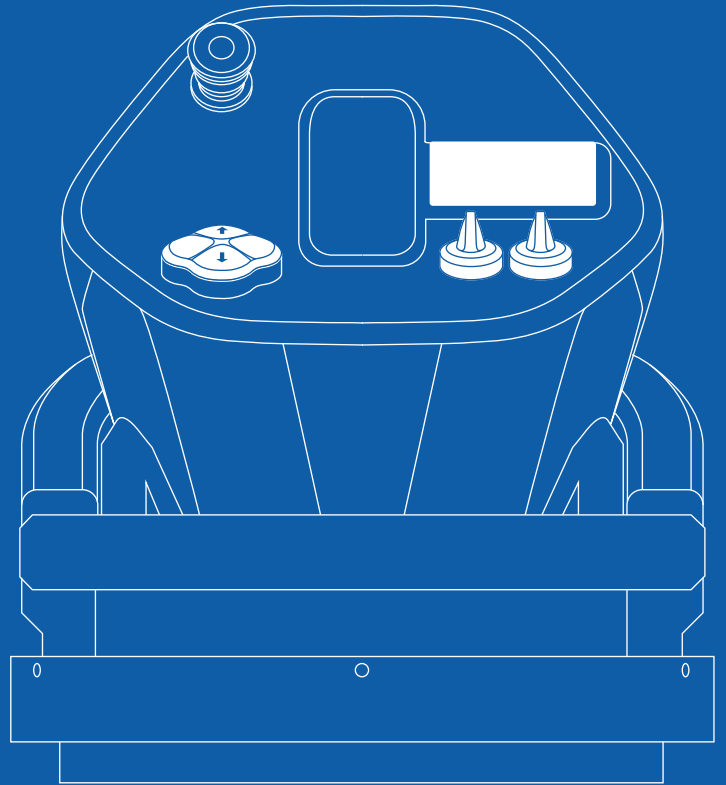

We proudly represent one of the leading Italian companies in the metal-mechanical sector, specializing in manufacturing diamond tools, machines and plants for processing ceramic, natural and synthetic stone.

Internationally acclaimed, we boast the highest number of patents, utility models, and industrial designs in the stone industry, filed, extended, and confirmed on a global scale.



Master 5000

Innovation and Tradition in Stone Processing

With over thirty years of excellence in the field of stone processing machines, we are proud to introduce the Master5000, a revolutionary contouring machine that represents the pinnacle of our technological evolution. Designed to precisely contour, drill, and polish marble, granite, and other stone materials, the Master5000 blends the solidity of traditional methods with the latest technological innovations. This historic model, which has shaped the landscape of stone processing, has been completely revamped to meet the demands of the most exacting professionals and to ensure unmatched performance. The Master5000 is not just a machine, but a legacy of quality and reliability, designed to transform your business and propel the art of stone processing into the future.





Why process with Master 5000?

You don't need a stationary CNC machine: our Master 5000 replaces numerous needs in terms of both space and time. The new manual CNC can cut and polish internal and external surfaces and profiles. It can shape complex contours very precisely and on materials of any kind.

➤ The new Marmoelettromeccanica manual contouring machine offers manufacturers the ability to work with any material in complex shapes, providing a high-quality product and significant time savings.

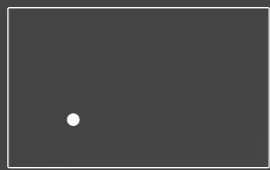
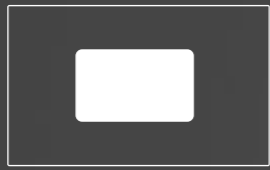
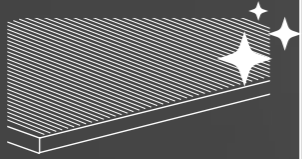
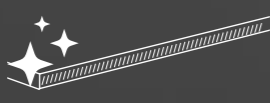
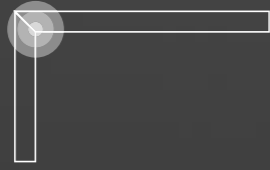

- **Profiling** 
- Drilling** 
- Sink Hole** 
- Slab Polisher** 
- Edge Polisher** 
- 45° Mitre** 



New intelligent functions



Off

Safety in the workshop is paramount, and the Master5000 is designed with the operator's peace of mind in mind. The "Off" button of the Master5000 is backlit to ensure optimal visibility in any situation. This feature allows operators to clearly see if the machine is in operation and to act quickly in case of an emergency.



Motorized Z-Axis

The motorized movement of the Z-axis simplifies and speeds up the adjustment of the grinding wheel's height. This feature enhances the usability and efficiency of the Master 5000.



Parameters Display

the Z-axis positioning is displayed on the screen, providing real-time feedback and high precision.



Speed Controllers for Z-Axis and Rotation Speed

The Master5000 elevates the art of stone processing with its innovative control features. Equipped with two intuitive selectors, this contouring machine allows for the adjustment of both the Z-axis speed and the tool rotation speed. This flexibility ensures that every type of processing, from the simplest to the most complex, is performed with utmost precision and adaptability.





Quick-Connect Tool

The quick-release grinding cone is ideal for those seeking efficiency and speed. This component is designed to facilitate a quick and safe replacement of the grinding wheel, optimizing work times and increasing productivity in the workshop.

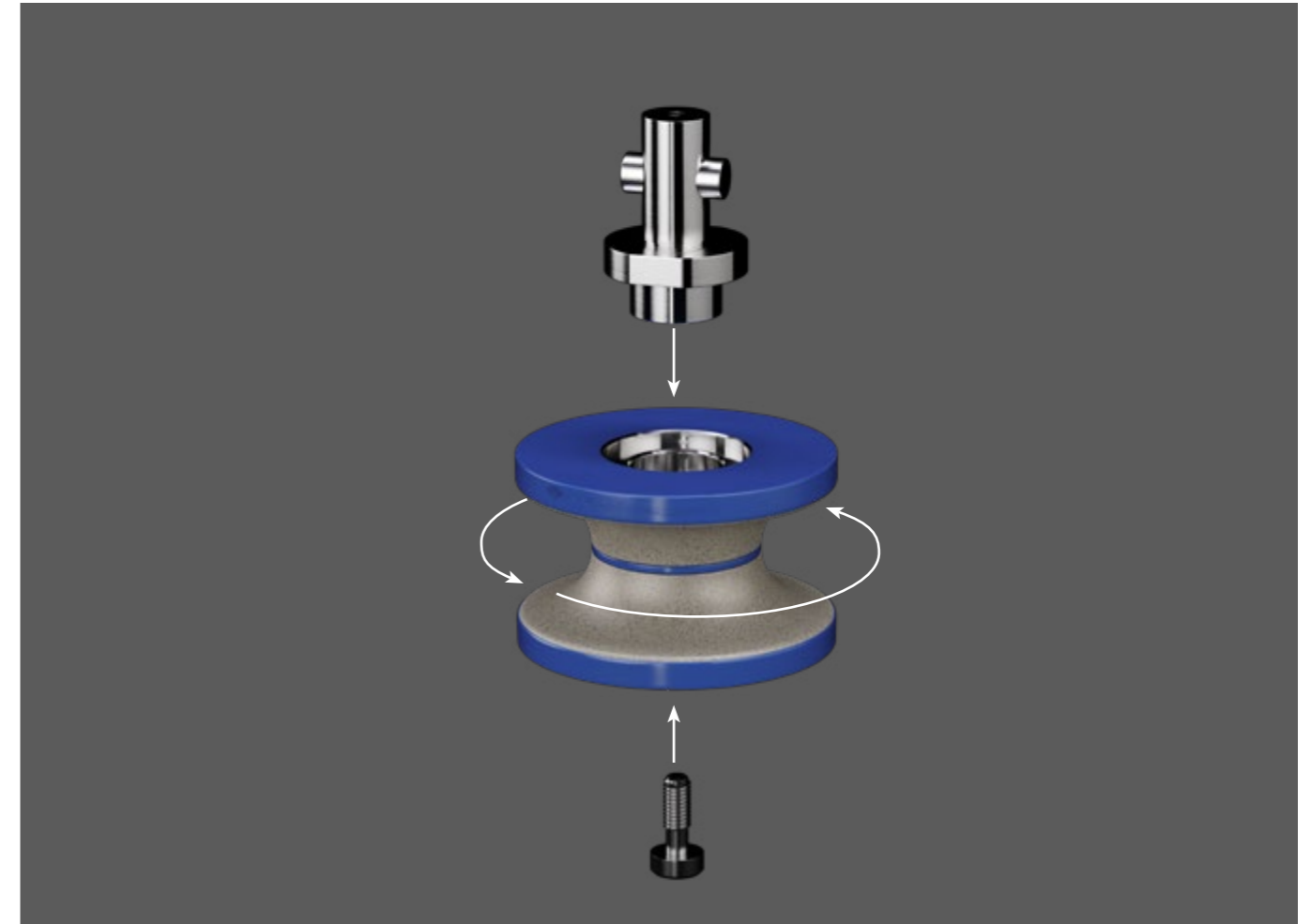
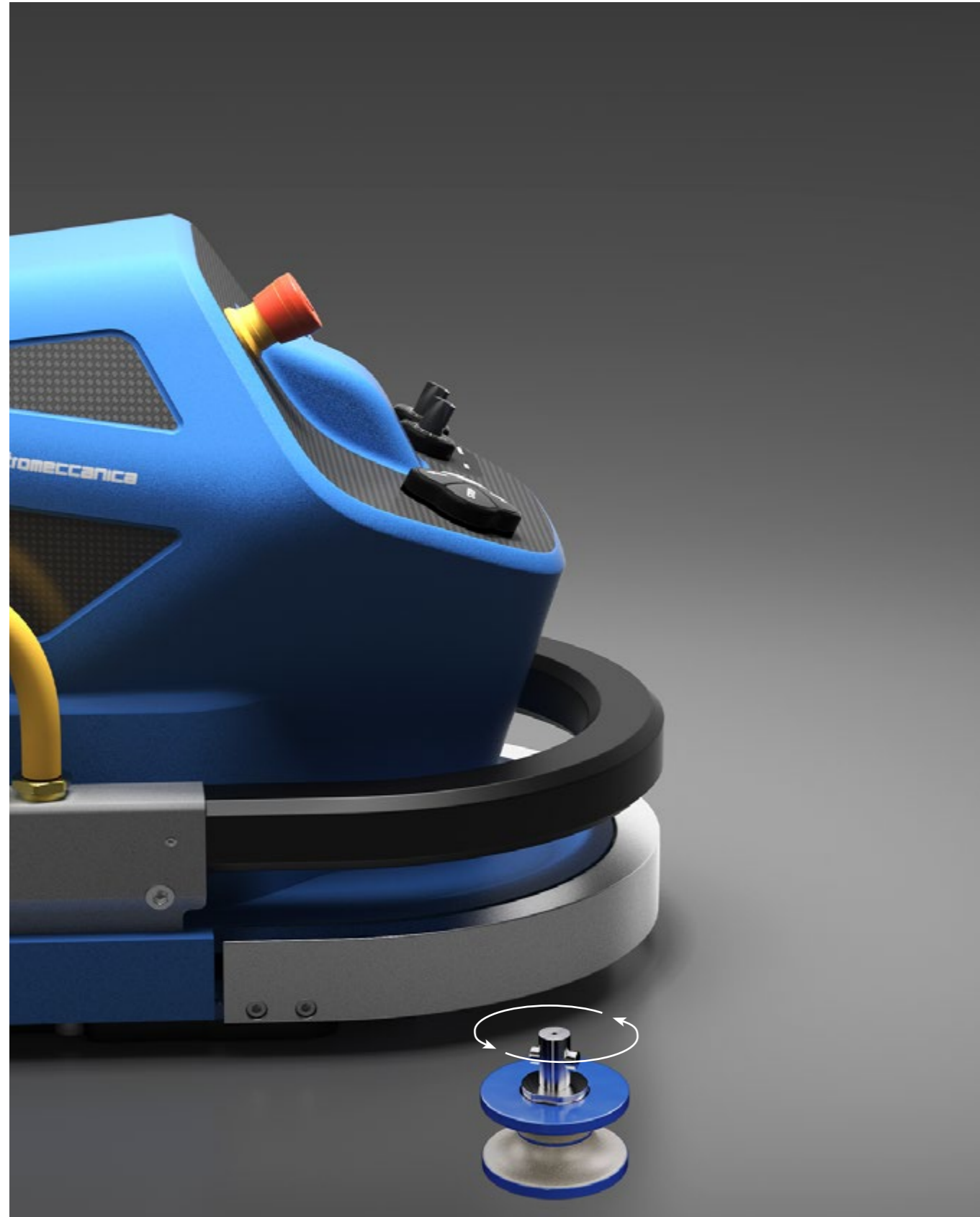

Quick Release

Thanks to the quick-release attachment system, the grinding wheel can be changed in just a few seconds. This feature is essential for minimizing interruptions during tool changes.

Stainless Steel

The attachment is made from stainless steel, known for its exceptional resistance to corrosion and rust. The use of this material ensures greater durability and maintains the structural integrity of the grinding cone over time.

Robust Design

The design of the cone has been developed to ensure maximum stability and safety during use. The stainless steel contributes to the robustness of the cone, ensuring that it remains reliable under stress.

Water System Plate

The Water System Plate is designed to enhance performance by allowing it to glide over a thin film of water. This unique feature ensures exceptionally smooth operation, preventing scratches on the surfaces of the materials being processed.

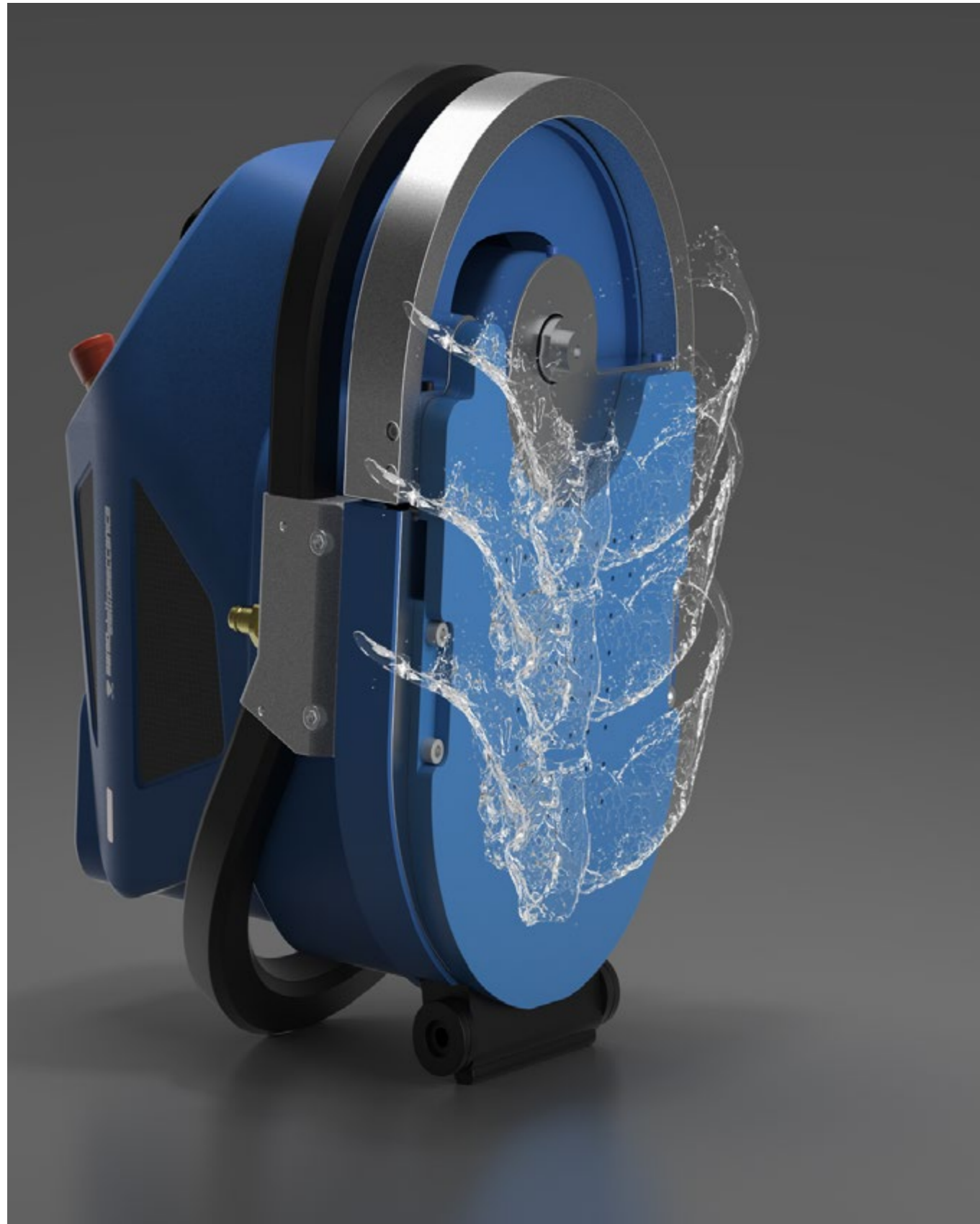

- Smooth Operation**
The water film between the machine and the material ensures that the Master 5000 moves effortlessly, reducing friction and preventing scratches on delicate surfaces.
- Unique Design**
Developed by Marmoelettromeccanica, this system is considered the best on the market. Its design not only improves operational fluidity but also contributes to the overall efficiency of the Master 5000.
- Reliability and Durability**
The Water System Plate is built to last. It does not clog or stop, ensuring continuous operation and long-lasting performance.

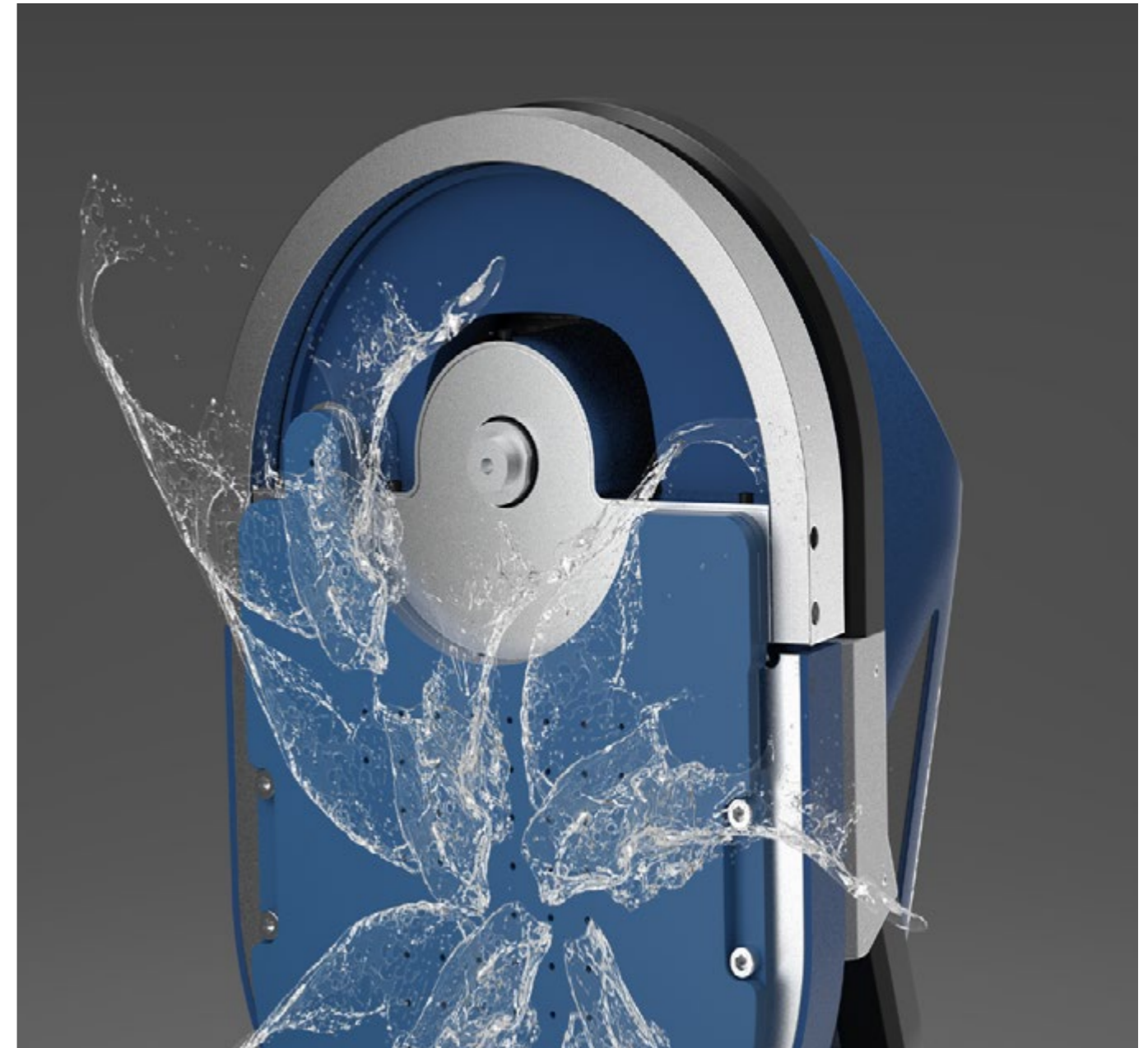



Motorized Z-Axis

The motorized movement of the Z-axis simplifies and speeds up the adjustment of the grinding wheel's height. This feature enhances the usability and efficiency of the Master 5000. Additionally, the Z-axis positioning is displayed on the screen, providing real-time feedback and high precision. This allows the operator to easily set a specific measurement, simply moving to the desired position for the execution of the task. This integrated system ensures accurate and efficient processing, reducing setup times and increasing productivity.



Speed Controllers for Z-Axis and Rotation Speed

The speed controllers for the Z-axis and rotation speed are crucial components for maximizing flexibility and efficiency in processing various materials. The Z-axis speed controller allows for precise control during delicate operations such as drilling, adapting to the specific needs of each material and process. This ensures optimal results without compromising quality. Similarly, the rotation speed controller is essential for setting the optimal speeds for each type of tool, whether it's a drill bit, a cutting mill, diamond grinding wheels, or polishing wheels. This flexibility in settings not only ensures maximum cutting and polishing effectiveness but also protects the tools from premature wear, significantly extending their useful life.



- Increased Precision**
The ability to finely adjust the Z-axis and rotation speeds ensures maximum precision in processing.
- Versatility**
With speed adjustment, operators can easily switch between different types of processing and materials, increasing the versatility of the Master 5000.
- Tool Durability**
Setting the appropriate speed for each tool prolongs the life of the tools themselves.



Safety and Efficiency at Low Voltage

The Master 5000 is designed to ensure maximum safety in any work environment, operating at a low voltage of 48 volts. This makes it particularly safe for operators working in the presence of water. The low voltage also ensures the power and effectiveness of the machine, delivering high performance in all conditions of use.

The Master 5000 combines advanced technology with uncompromised safety, setting new standards in the industry for operator protection and operational effectiveness.



Low Voltage, High Safety

Operating at only 48 volts, the Master 5000 provides a safe working solution even in damp environments. This aspect is crucial for preventing injuries and ensuring workplace safety. It has been developed to ensure maximum stability and safety during use. The stainless steel contributes to the robustness of the cone, ensuring that it remains reliable under stress.



Ideal for Wet Environments

Its compatibility with wet environments makes it the ideal choice for sectors such as marble processing and other applications that require the presence of water during the process.



The Safest Machine in its Category

Thanks to its low voltage configuration and other integrated safety measures, the Master 5000 is considered the safest machine in the world in its category, offering complete peace of mind to operators.

High Versatility and Power Machine



This machine is designed to operate at voltages of 110 volts or 220 volts, making it suitable for use in any workshop or construction site. This versatility in power supply ensures that the machine can be easily integrated into various work environments without the need for special adapters or transformers.

The Master 5000 combines excellent power and operational flexibility, setting new standards of versatility and reliability in its field, and ensuring high-performance levels in every usage condition.



Dual Voltage Option

With the ability to function at both 110 volts and 220 volts, the machine offers unprecedented flexibility, easily adapting to both small artisan workshops and large industrial sites.



Guaranteed Power

A consumption of 1500W for 220 volts and 14Ah for 110 volts ensures that the machine has the necessary power for heavy and continuous operations, maintaining high standards of efficiency and productivity.



Ideal for Any Environment

Its ability to operate with different voltages makes it ideal for international use, overcoming barriers that often limit the use of heavy machinery due to local power specifications.

Master 5000: Built to Last

The Master 5000 is entirely constructed from stainless steel and aluminum, materials chosen to ensure maximum durability and resistance over time. This combination also provides superior resistance to corrosion, wear, and environmental stress.

Previous versions of the Master have proven their reliability and longevity, with machines still operational after more than 30 years of intensive service. This impressive track record is a testament to the outstanding quality and longevity of the Master machines.

The Master 5000 reduces the need for maintenance and replacement. It is ideal for those looking for a reliable product that will ensure excellent performance for decades.

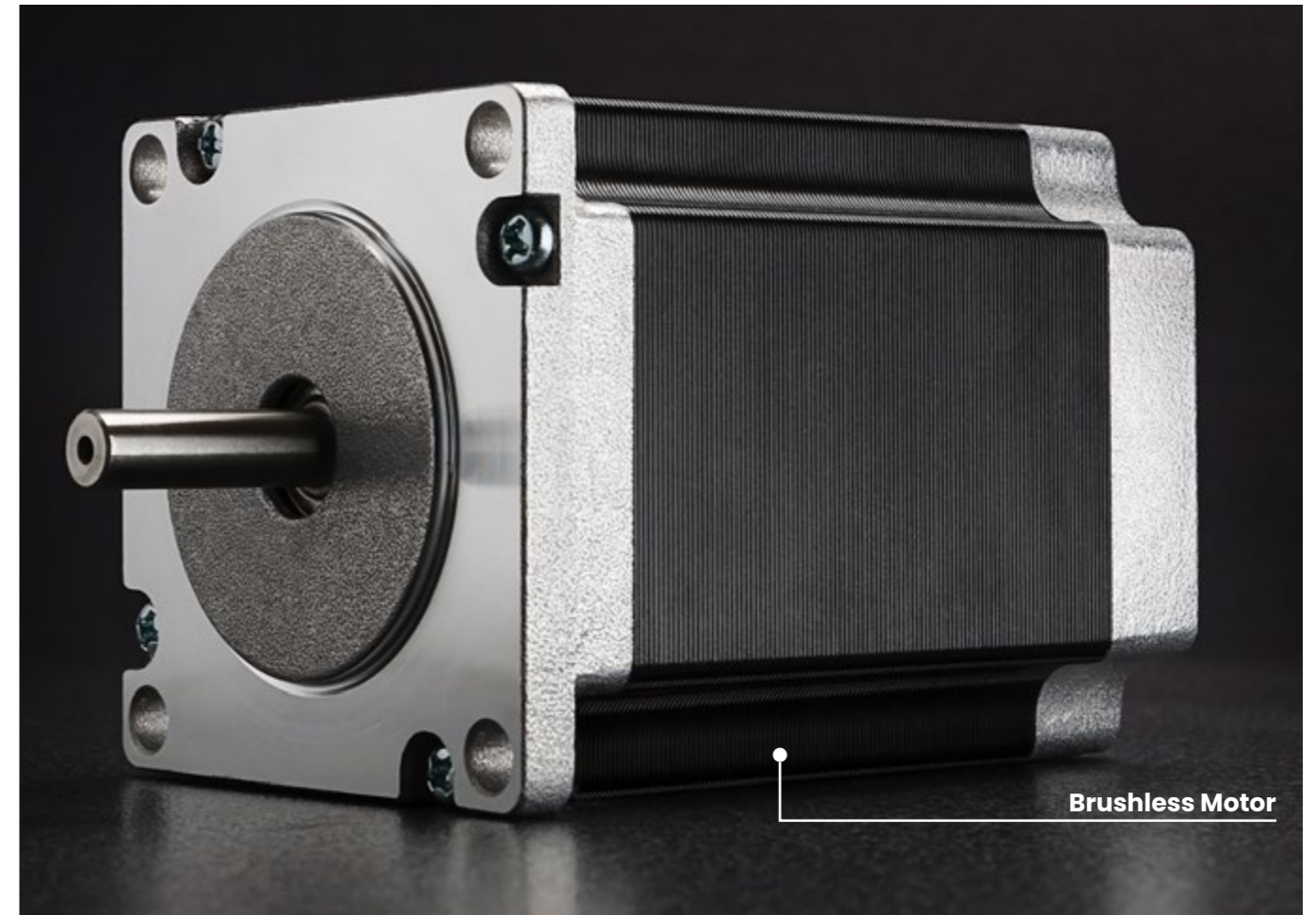
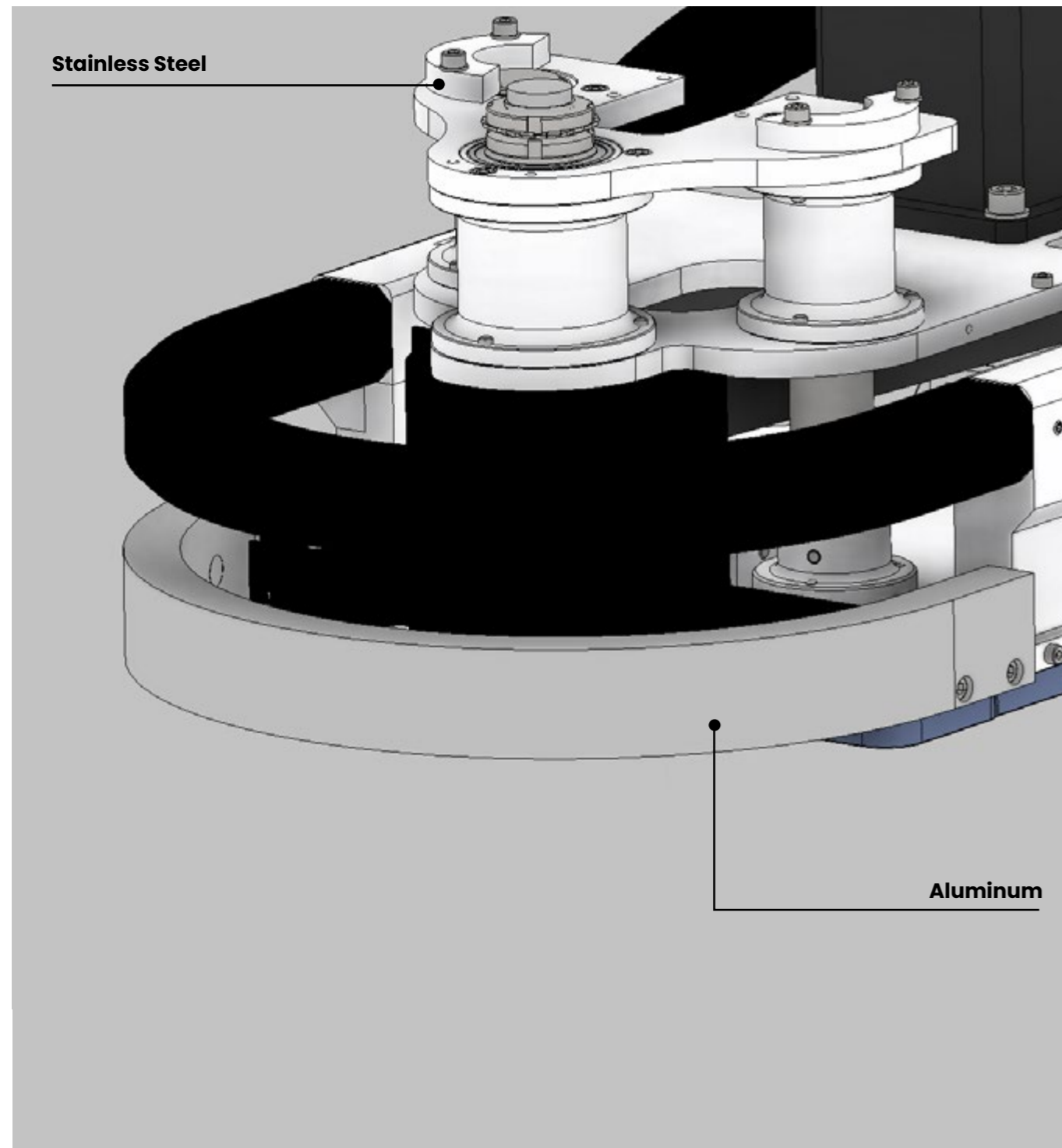

Brushless Motor: Efficiency and Superior Performance

The Master 5000 is equipped with a state-of-the-art brushless motor, a technological choice that brings numerous advantages in terms of efficiency and performance. The brushless motor, being devoid of brushes, significantly reduces internal friction, resulting in smoother and quieter operation.

The Master 5000 with a brushless motor represents the pinnacle of technology in terms of mechanical and electrical efficiency, guaranteeing users superior performance and reduced operating costs, making every job simpler and more productive.



Energy Efficiency

Brushless motors are known for their high energy efficiency. They consume less power and produce more output per watt compared to traditional brushed motors, reducing operational costs and environmental impact.



Increased Durability

With no brushes, the brushless motor has fewer parts that wear out, significantly extending the motor's lifespan. This translates into less maintenance and fewer replacements needed.



Enhanced Performance

The brushless motor ensures constant power output at both low and high speeds, thus ensuring maximum performance.



Reliability

With fewer mechanical components subject to wear, brushless motors offer greater reliability and consistent performance, even under heavy loads and in challenging operational conditions.



Work Steps for internal and external profiling

From Quick Contouring to Perfect Polishing

For every edge in granite, quartz, ceramic, marble, and other materials, our technology allows for a transition from rapid contouring to impeccable polishing. With over 200 standard profiles available in stock, the possibilities for customization are endless. Furthermore, we create profiles based on specific customer requests, ensuring tailor-made solutions for every need.

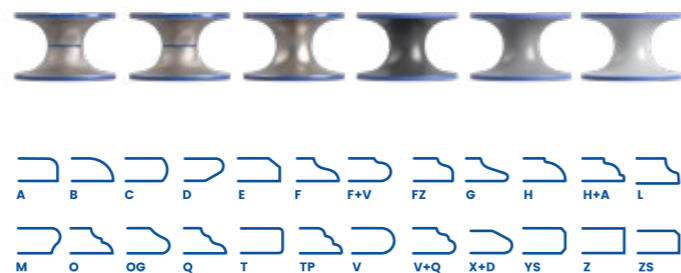

Work Steps for Sink Hole



Drilling and Cutting with the Master 5000

The Master 5000 enables the use of drill bits for drilling and end mills for precise cutting. To fully exploit these features, the sink device is necessary, an indispensable accessory that expands the machine's operational capabilities, making it even more versatile and suitable for meeting every specific processing requirement.

Designed for Kitchen Countertop Fabrication

The Master 5000 is engineered to meet the needs of those working with kitchen countertops, offering the capability to install 20 mm grinding wheels with a half-gas attachment. This allows for the creation of internal holes up to a radius of 10mm, from roughing to perfect polishing.



* For the use of this accessory, it is necessary to have the appropriate Work Device bench.



Work Steps for Polishing Slabs

Polishing, smoothing, and brushing finishes

The Master5000 stands out for its ability to completely transform the slabs in your warehouse, precisely meeting the specific requirements of each customer. Thanks to the use of a dedicated accessory, this machine allows for polishing, smoothing, and brushing a wide range of materials such as marble, granite, travertine, and limestone with ease and speed. The versatility of the accessory enables operators to quickly adapt to different finishing needs, significantly increasing the efficiency of the workshop. With its advanced features, the Master5000 is the ideal solution for workshops looking to elevate the quality and variety of their work, ensuring exceptional results and customer satisfaction in every project.



STEP 1 – Metal Diamond Plate



STEP 2 – Polishing Diamond Plate



* For the use of this accessory, it is necessary to have the appropriate Work Device bench.

Work Steps for Inline Polishing



ONLY ONE STEP – From Grinding to Polishing

Polishing on the straight edge in a single pass

Optimize your workflow and maximize efficiency in your workshop with the Master5000, thanks to its innovative accessory that transforms it into a high-level manual edge polisher. Equipped with a special head that mounts four tools, the Master5000 allows for the polishing of various materials on the straight edge in a single pass. This configuration not only ensures an impeccable finish but also offers significant time savings. With the Master5000, you can replace manual polishing processes with an automatic, efficient, and highly productive solution. Discover how the Master5000 can revolutionize surface treatment in your workshop, ensuring superior results with less effort.

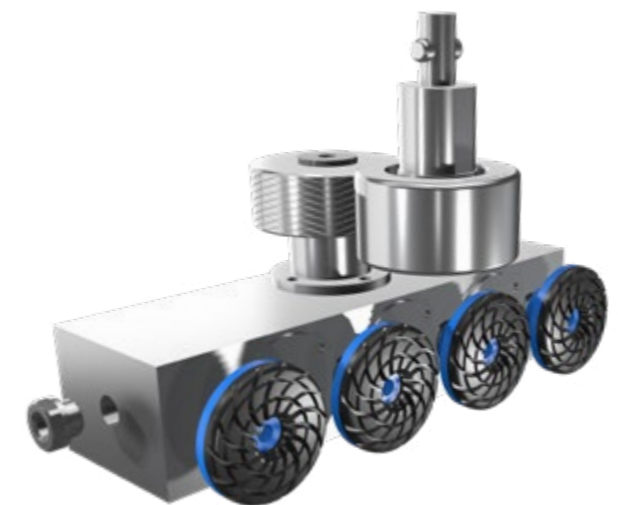

* For the use of this accessory, it is necessary to have the appropriate Work Device bench.

Work Steps

for 45° Mitre

Flawless 45° cuts on a wide range of materials

Maximize precision and efficiency in your workshop with the Master5000's 45° Mitre Accessory, designed to execute flawless 45° cuts on a wide range of materials. This accessory allows for perfect cuts in a single pass, ensuring quick assemblies without any chipping. Ideal for working with ceramics, granite, and other natural materials, the 45° Mitre Accessory makes the operation extremely smooth, eliminating complications and reducing processing times. Its ability to make precise and clean cuts makes it an indispensable tool for those seeking high-quality results.

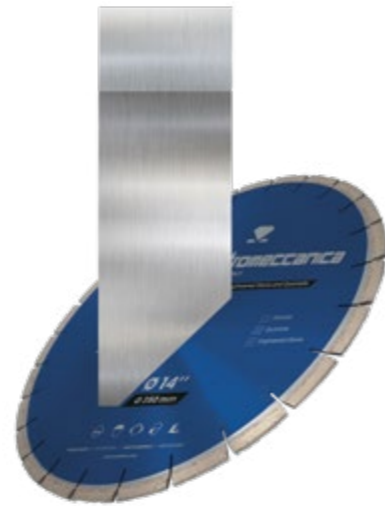

ONLY ONE STEP – Cutting Blades



* For the use of this accessory, it is necessary to have the appropriate Work Device bench.

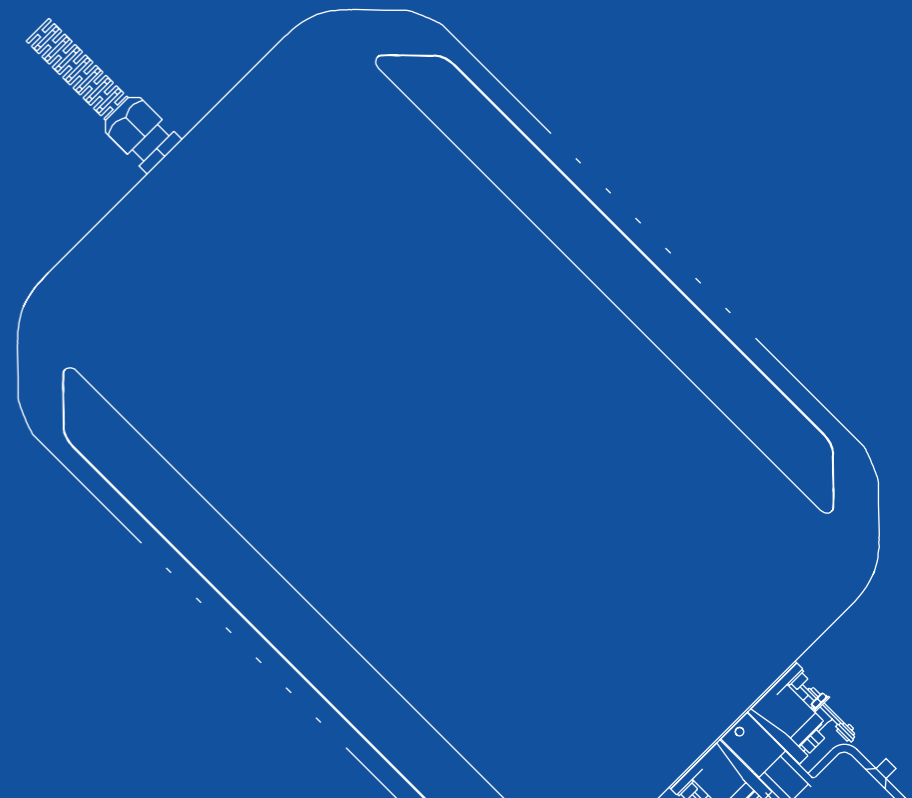
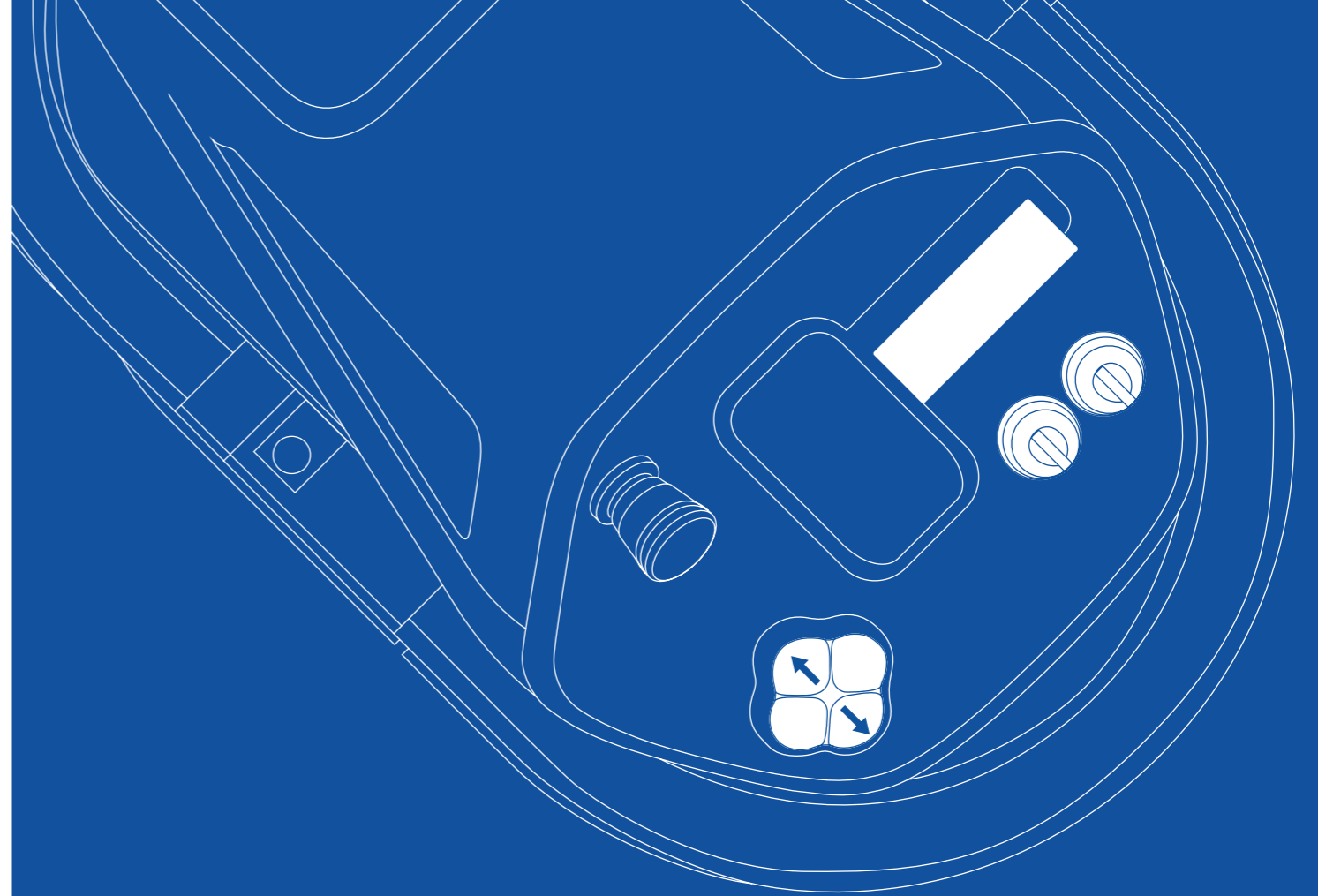



Master 5000

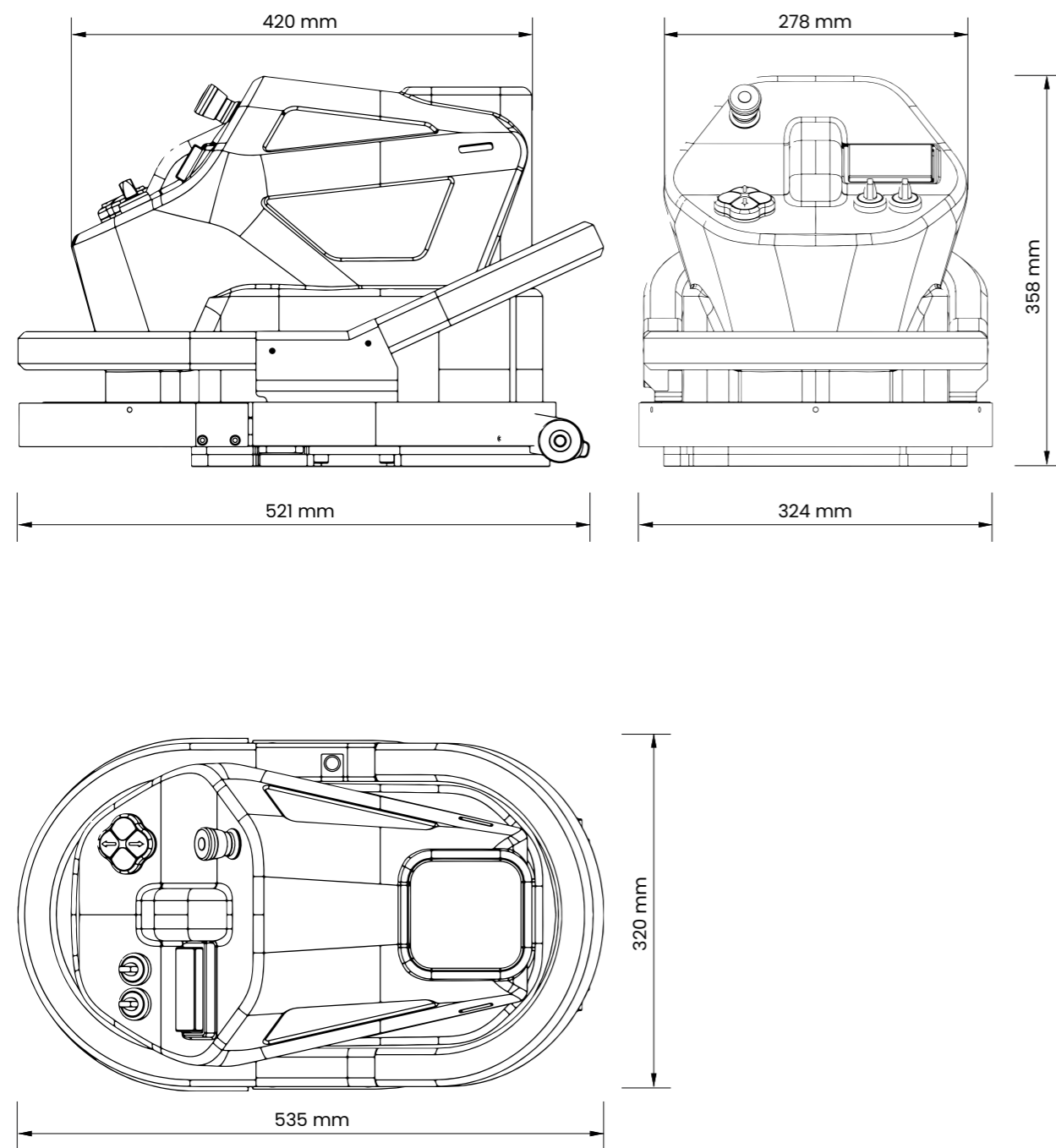

Electrical Conversion Unit

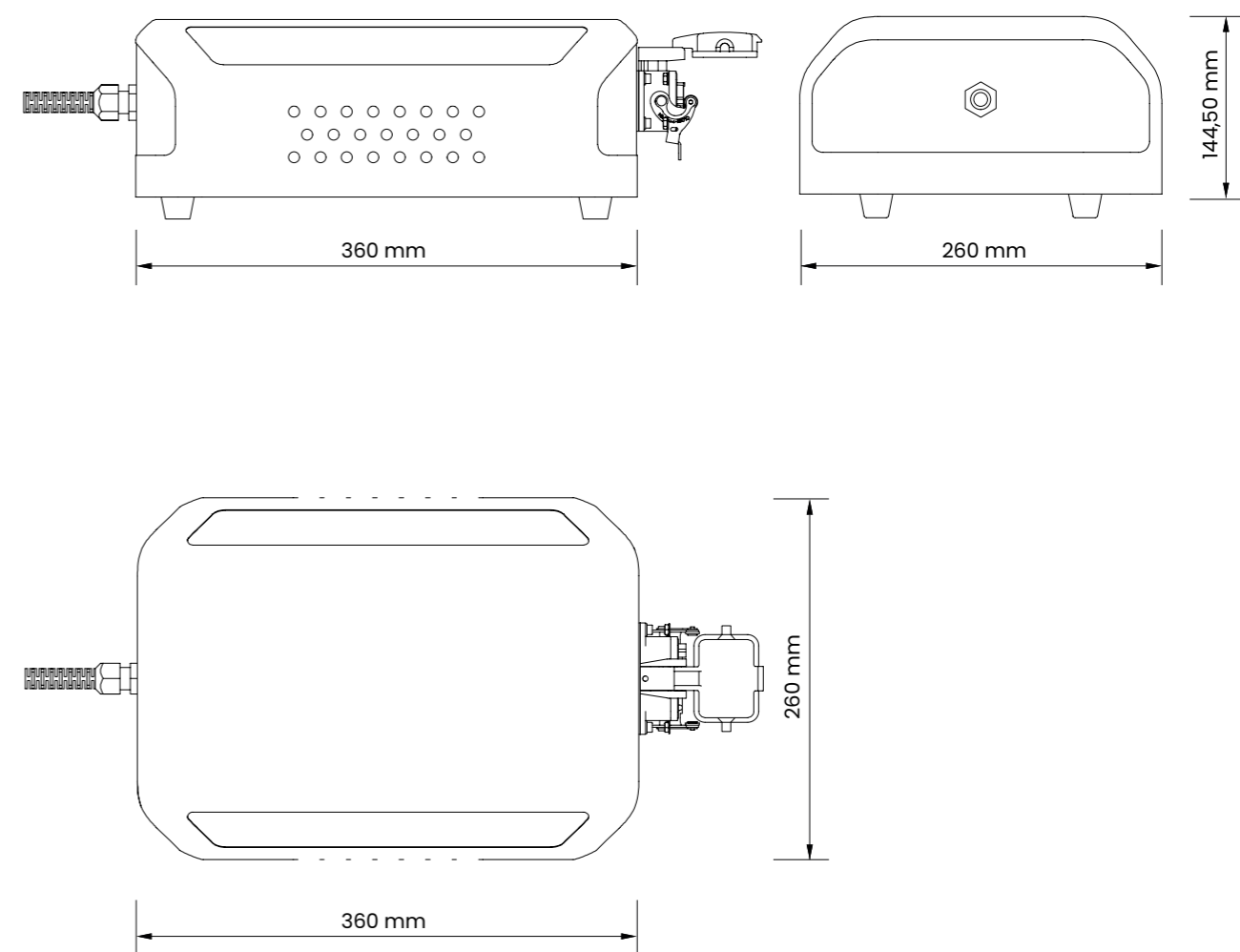



Detailed Description

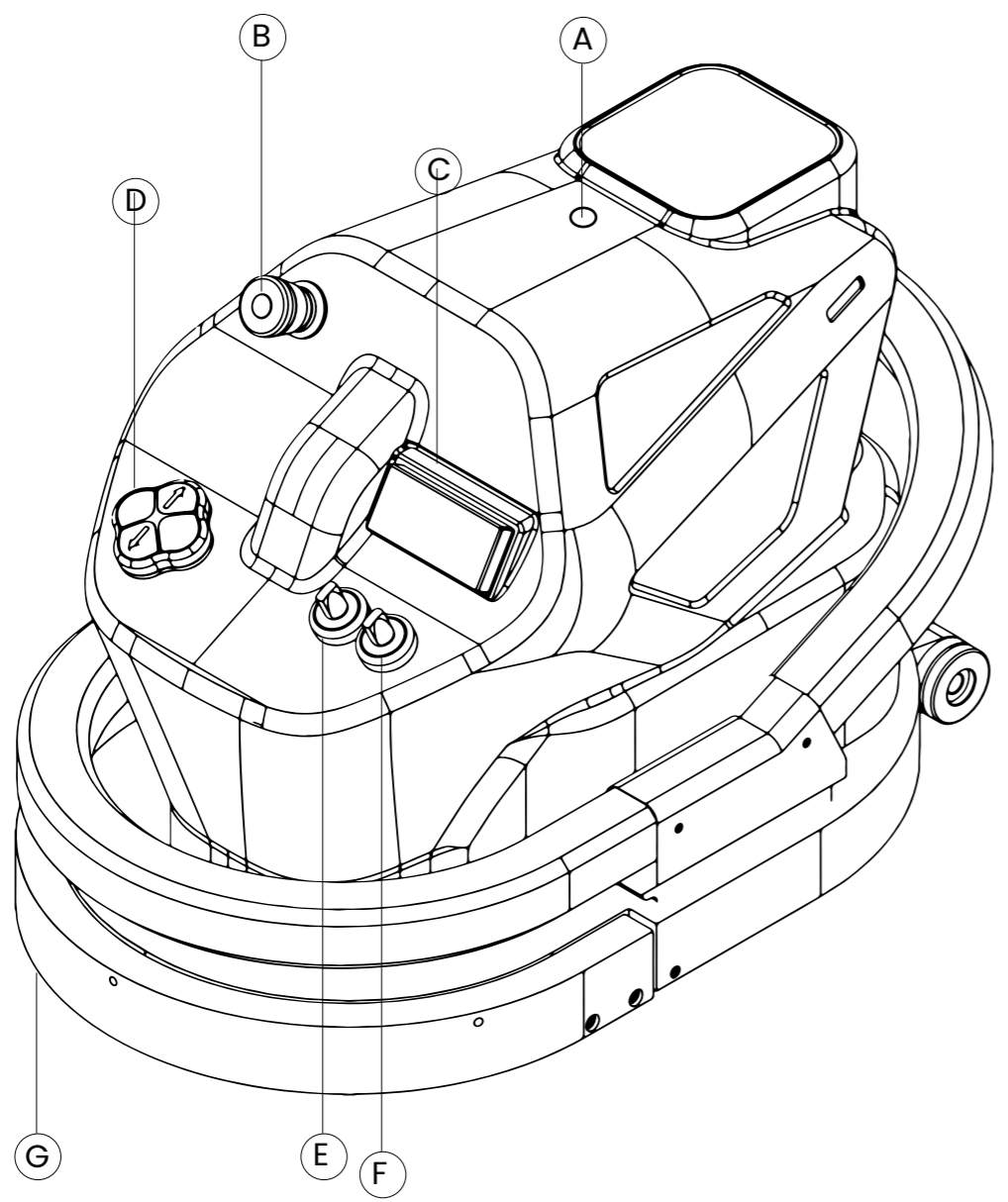

- A- Electrical cable.** the 48 volt current has to travel 6 metres long; the cable must always be connected to the central conversion unit by a special plug.
- B- Stop button.** Red stop switch is marked with "OFF" gives you the possibility to quickly turn off the machine even in an emergency.
- C - Monitoring display.** The positioning of the Z-axis is shown on the screen, providing real-time feedback and high precision.
- D - Adjustment buttons.** The height of the Z-axis is controlled and adjusted through the dedicated buttons.
- E- Speed Regulator.** The dedicated knob allows for complete control of the grinding wheel speed.
- F- Spindle Descent Speed Regulator.** The dedicated knob allows for precise control of the Z-axis adjustment.
- G- Water spray system.** The machine is equipped with 4 adjustable water jets and a system for washing the surface which ensures that the bits cool down and that dust does not build up.

Technical Data

MASTER 5000

VARIABLE SHAFT SPEED	RPM 500/6000
MECHANICAL STRUCTURE	Aluminum Stainless Steel
MOTOR	Brushless
HOUSING	MDPE
SPECIAL TREATMENT	Mechanical part: Anticorodal Aesthetic part: Heat painted
TYPE	100/r f3 RPM 1400/2800
TRASMISSION	Poly/v 12J
ISOLATION	CH Term 140°C

ELECTRICAL CONVERSION UNIT

ELECTRIC CONVERSION	1500 W
INPUT	110-220 volt
OUTPUT	48 volt

Packaging

MASTER 5000	
A	610 mm
B	410 mm
C	580 mm
Weight	35 kg

ELECTRIC CONVERSION	
A	480 mm
B	420 mm
C	400 mm
Weight	7 kg

